

- IT** Istruzioni per il montaggio
- EN** Installation instructions
- FR** Notice de montage
- DE** Montageanleitung
- ES** Instrucciones de montaje
- RU** Инструкции по монтажу
- NL** Montagevoorschrift

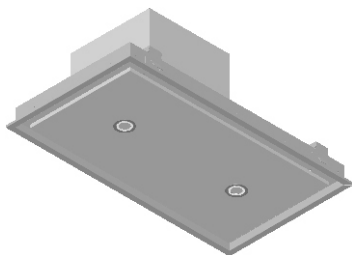

**FIM 662 P30**  
**FIM 6072 P30**  
motore removibile/removable motor

- IT** **ATTENZIONE!** La cappa aspirante è equipaggiata con materiale di fissaggio standard. Chi esegue l'installazione deve assicurarsi di utilizzare dispositivi di fissaggio idonei alle pareti e/o soffitti trovati. La ditta costruttrice declina ogni responsabilità per danni causati da montaggi non eseguiti correttamente.
- EN** **WARNING!** The hood is equipped with standard fixing material. The person who is mounting the hood should make sure that the fixing elements are right and suitable for the walls and ceilings he finds. The manufacturer declines any responsibility for damages caused by incorrect mounting.
- FR** **ATTENTION!** La hotte est équipée avec des matériaux standard pour le montage. Le monteur doit vérifier que les éléments de fixages sont appropriés aux parois et aux plafonds trouvés. La maison constructrice décline toute responsabilité pour des endommagements causés par de montages qui n'ont pas été faits de manière correcte.
- DE** **ACHTUNG!** Die Dunstabzugshaube ist mit Standard Befestigungselementen ausgestattet. Der Monteur muss sicherstellen, daß die vorhandene Befestigungselementen für die gefundenen Decken oder Wände geeignet sind. Die Herstellungsfirma lehnt jegliche Haftung ab, für Schaden die von falscher Montage verursacht worden sind.
- ES** **ATENCIÓN!** La campana extractora está equipada con herrajes de fijación standard. Quien ejecute la instalación debe asegurarse de utilizar dispositivos de fijación idóneos a la pared o techo que se encuentre. El fabricante declina cualquier responsabilidad en los daños causados por montajes no ejecutados correctamente.
- RU** **ВНИМАНИЕ!** Вытяжка поставляется со стандартным крепежным материалом. Тот, кто будет производить установку должен проверить, чтобы используемый крепеж соответствовал стенами и/или потолкам на месте установки вытяжки. Фирма-производитель не берет на себя никакой ответственности за ущерб возникший из-за произведения неправильного крепежа.
- NL** **ATTENTIE!** De afzuigkap is voorzien van standaard bevestigingsmateriaal. De monteur moet zich ervan overtuigen, dat het meegeleverde bevestigingsmateriaal geschikt is voor de plafonds en muren, waaraan de afzuigkap gemonteerd dient te worden. De fabrikant wijst elke aansprakelijkheid af voor schades die voortkomen uit foutieve montage.

**A**

**Montaggio con motore interno / Installation with internal motor**

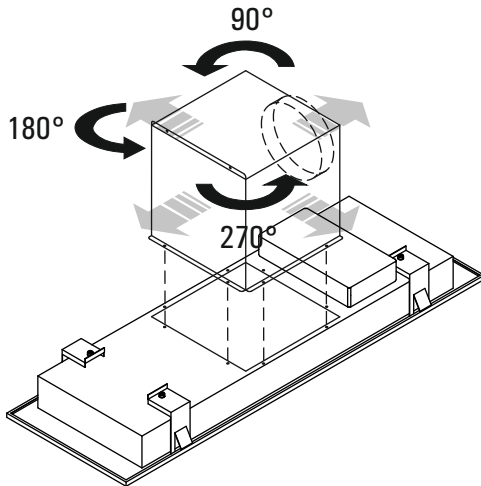
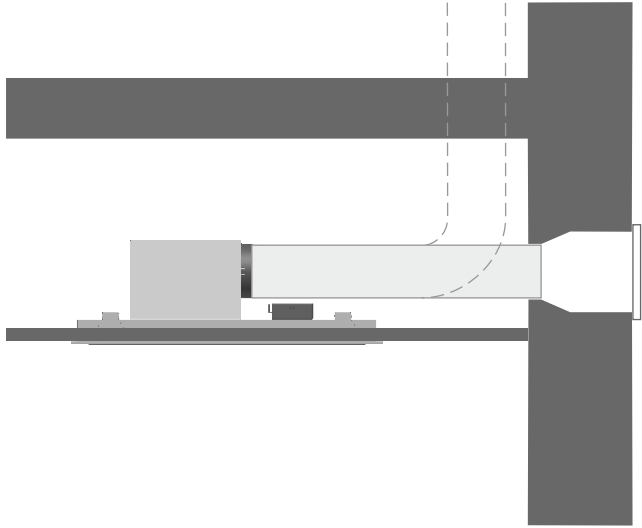
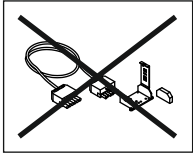
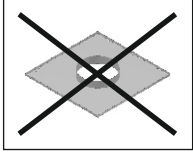
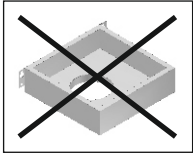

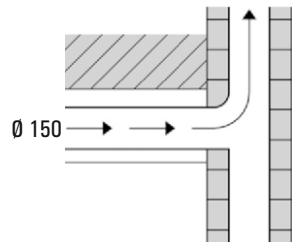
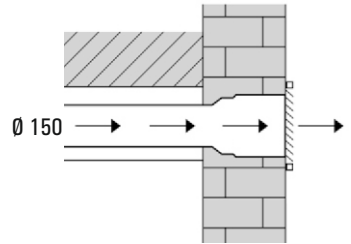
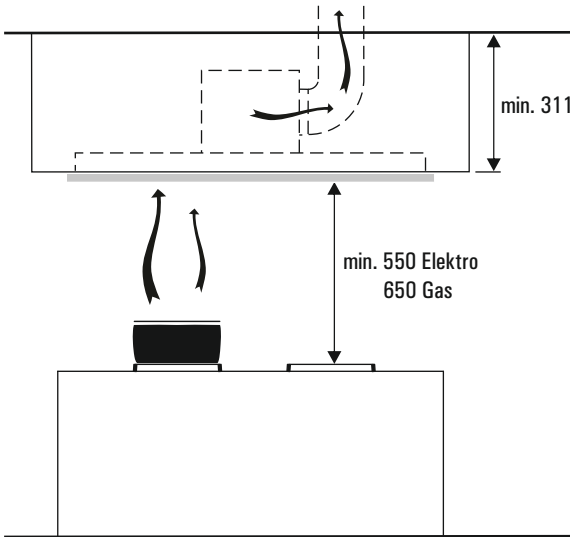
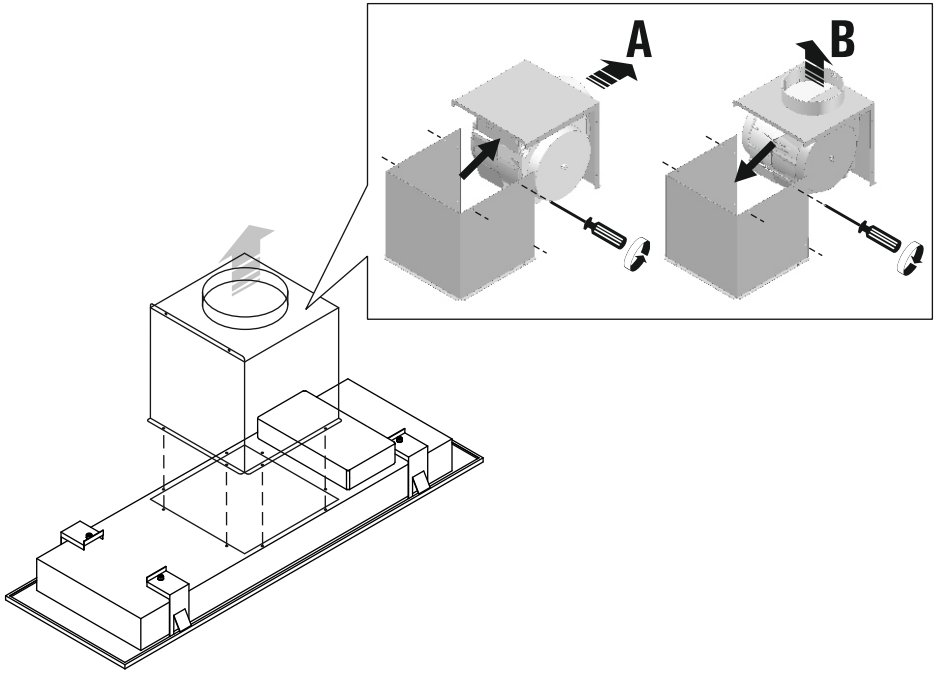

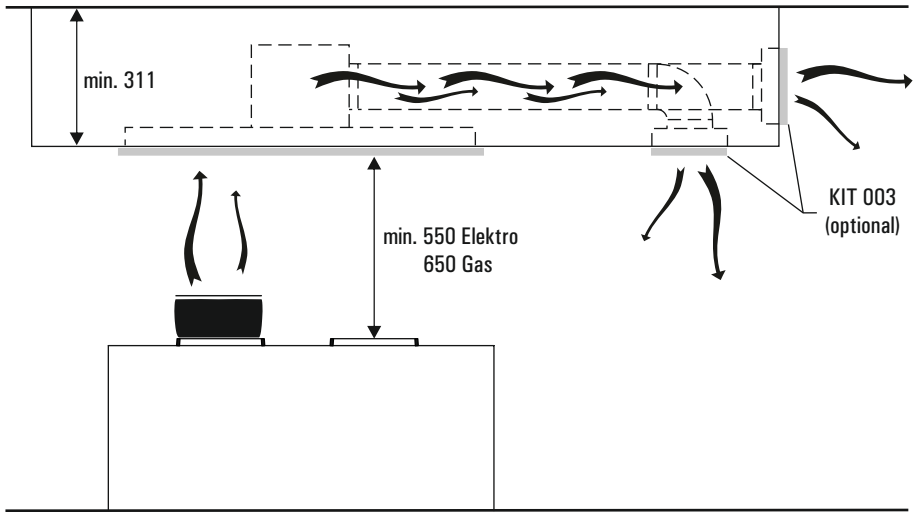

C 1

**B**

**Montaggio con motore removibile / Installation with removable motor**

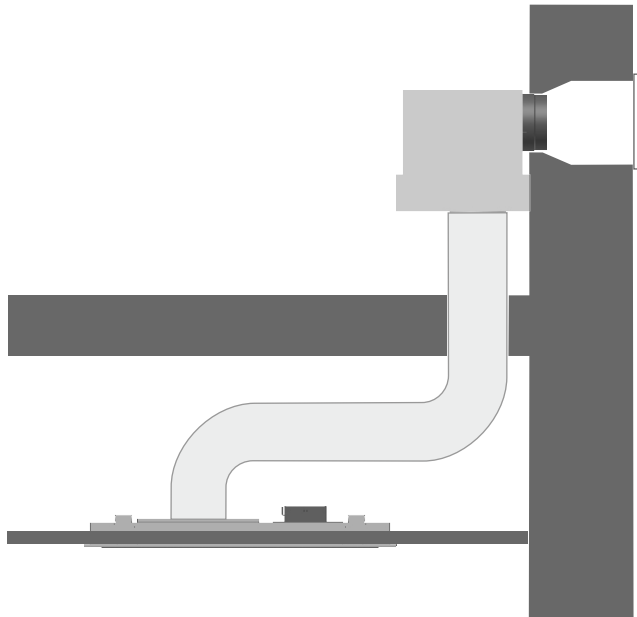
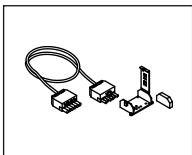
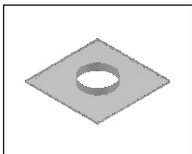
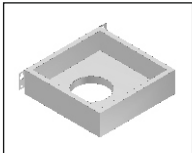

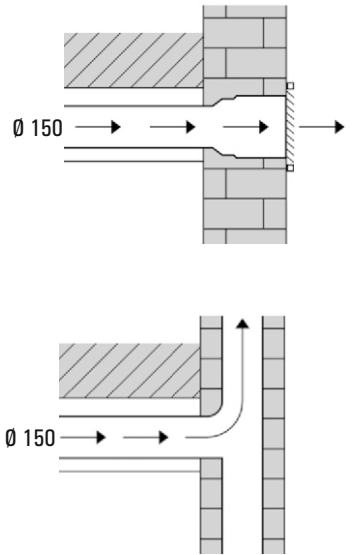
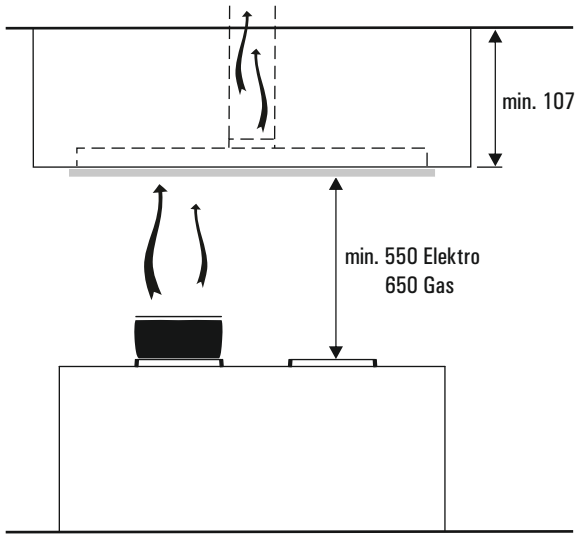
**B****M 1****A**

Mod.	X	Y
60x30	570	276
90x30	870	276
120x30	1170	276

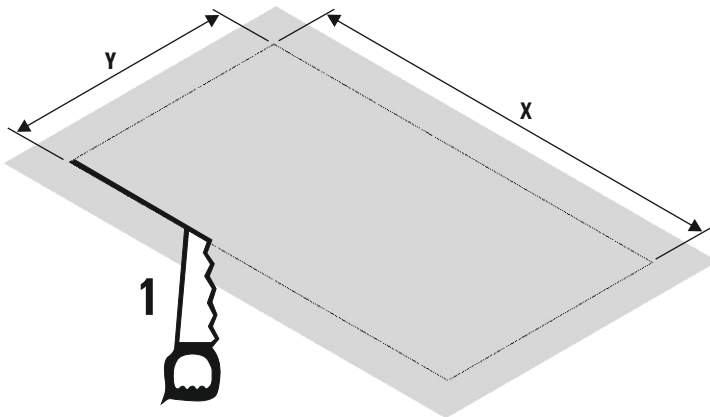
**B****M 2**

**A**

**B**

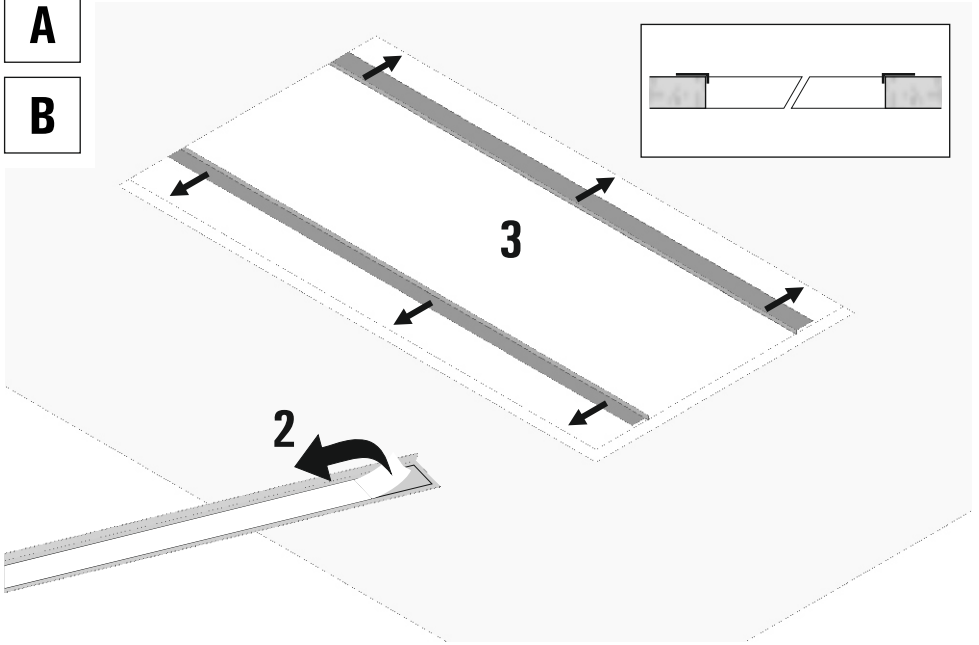

**M 3**

**A**

**B**

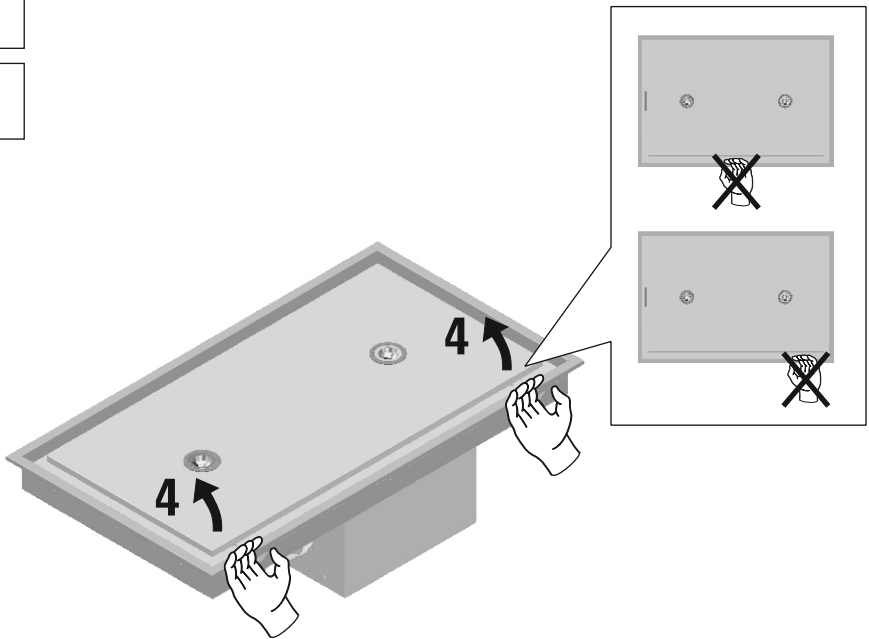

**M 4**

**A**

**B**

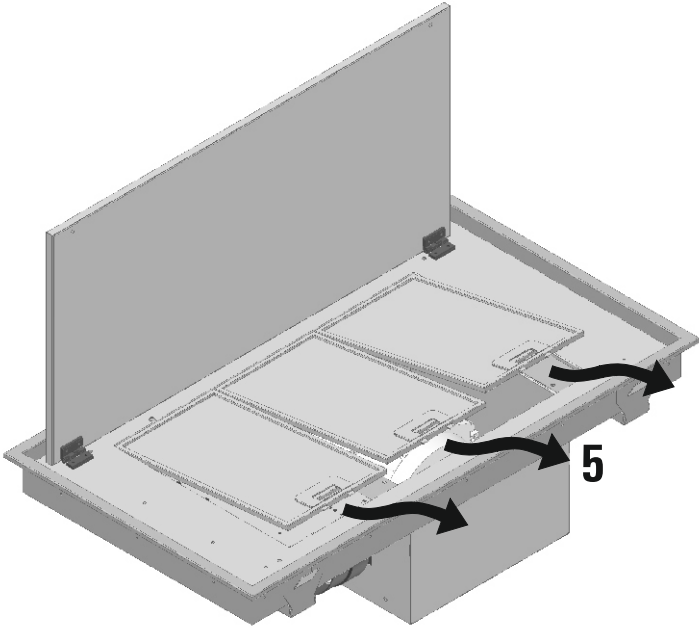

**M 5**

**A**

**B**

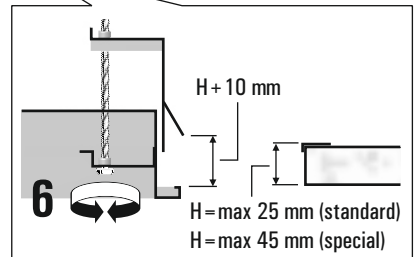
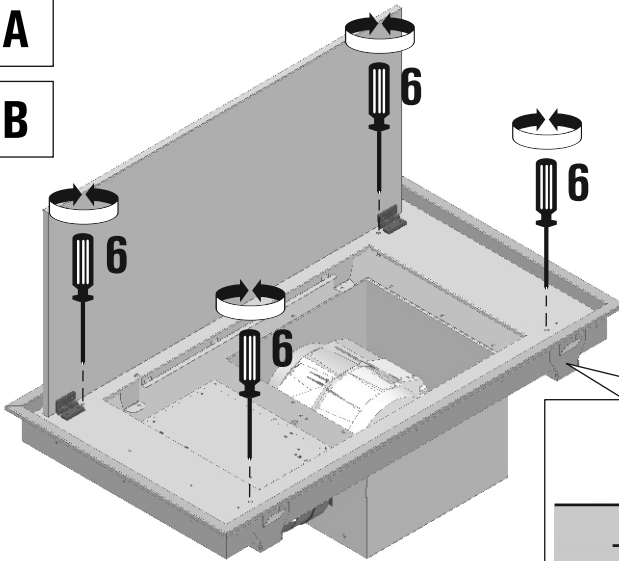

**M 6**



**A**

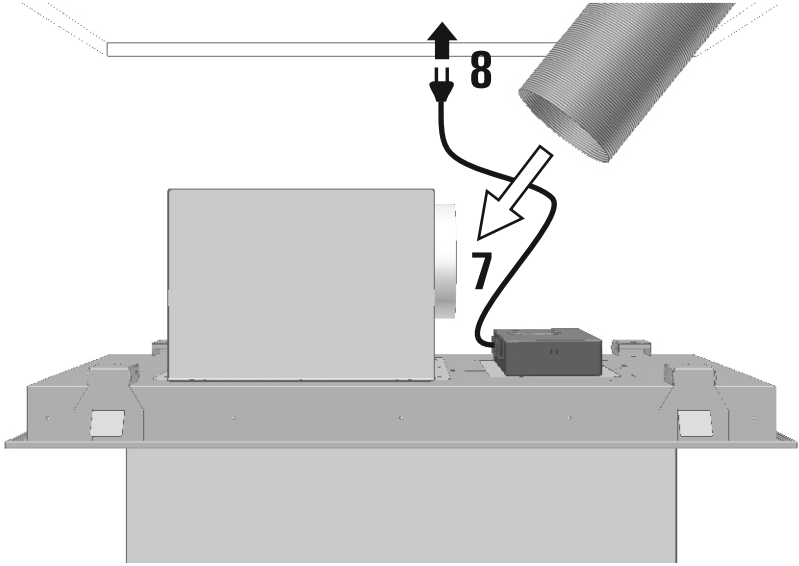

**M 7**

**A**

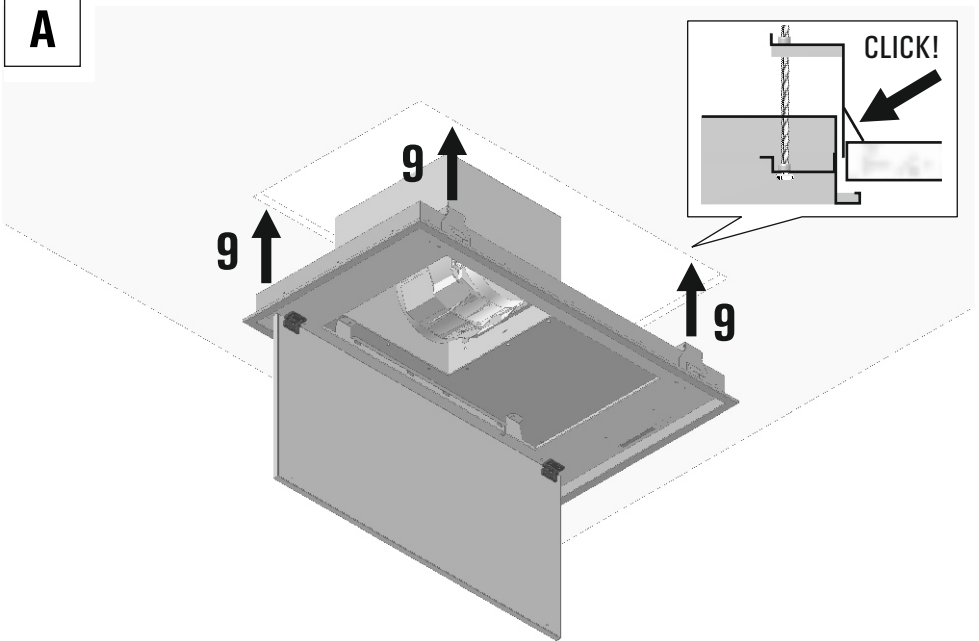

**M 8**

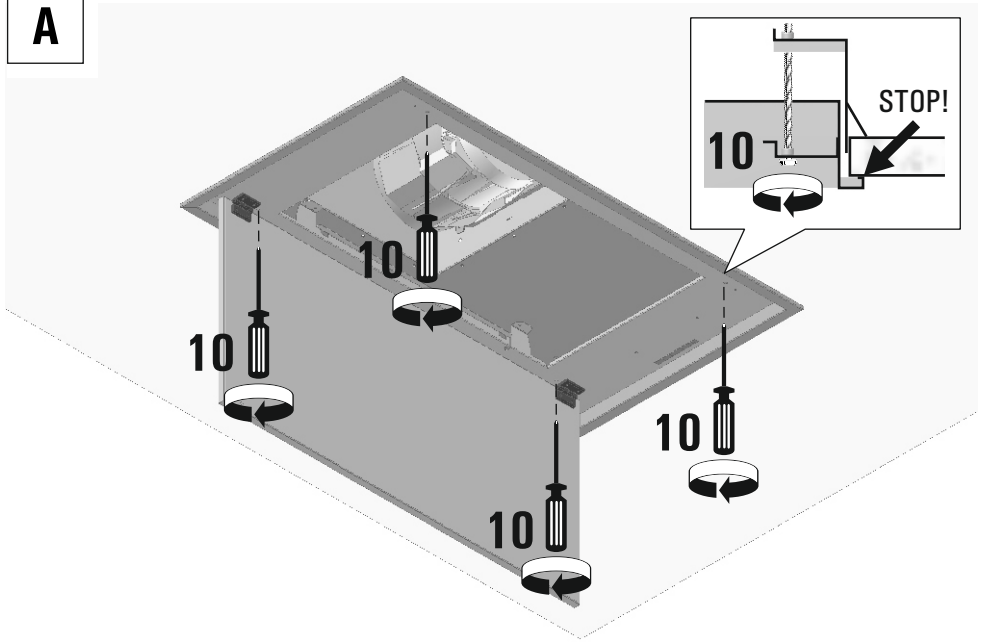
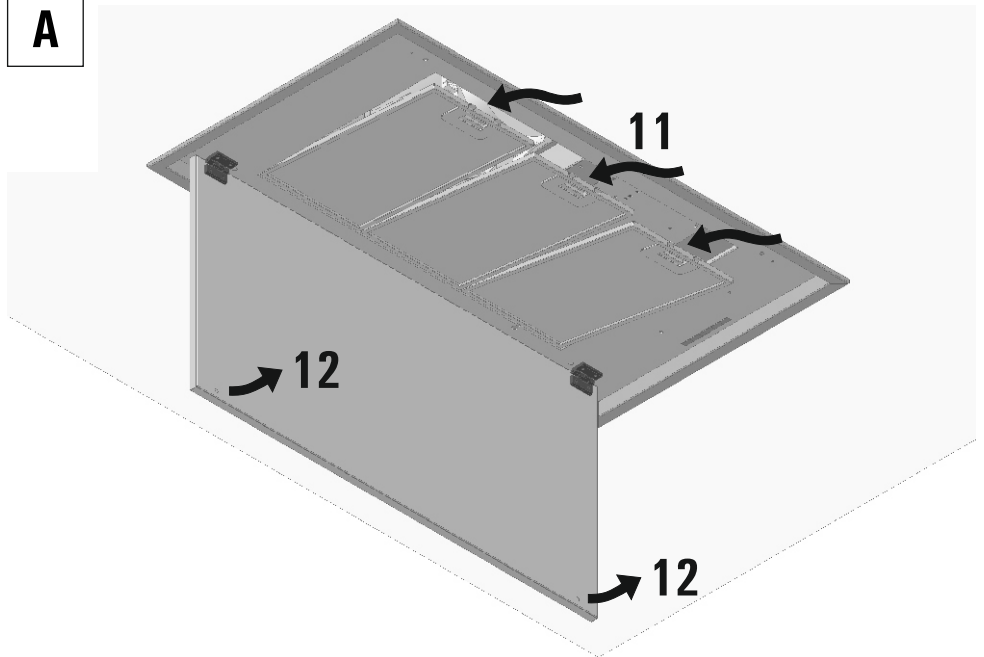
**A****M 9****A****M 10**

**B**

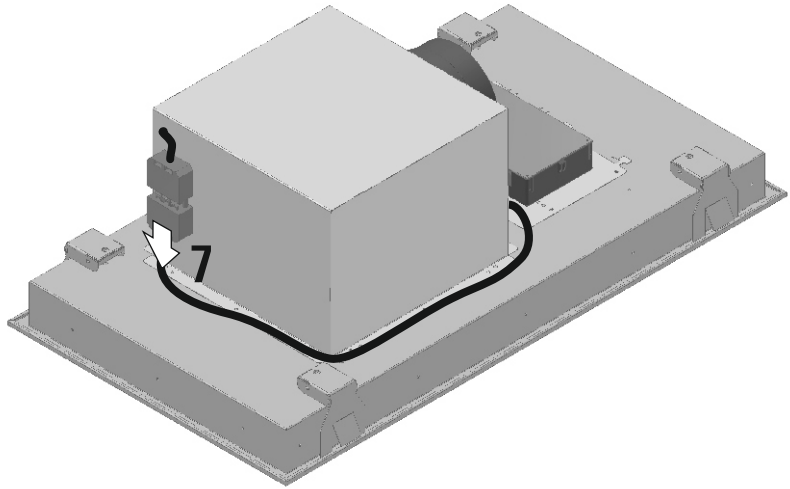

M 7

**B**

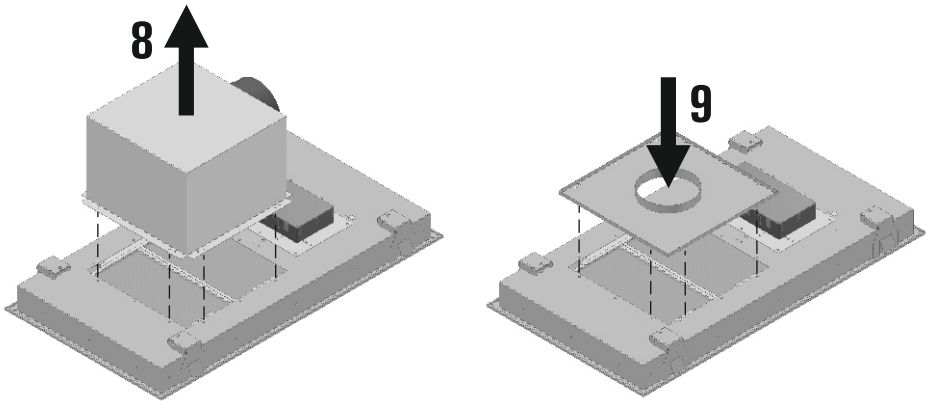

M 8

**B**

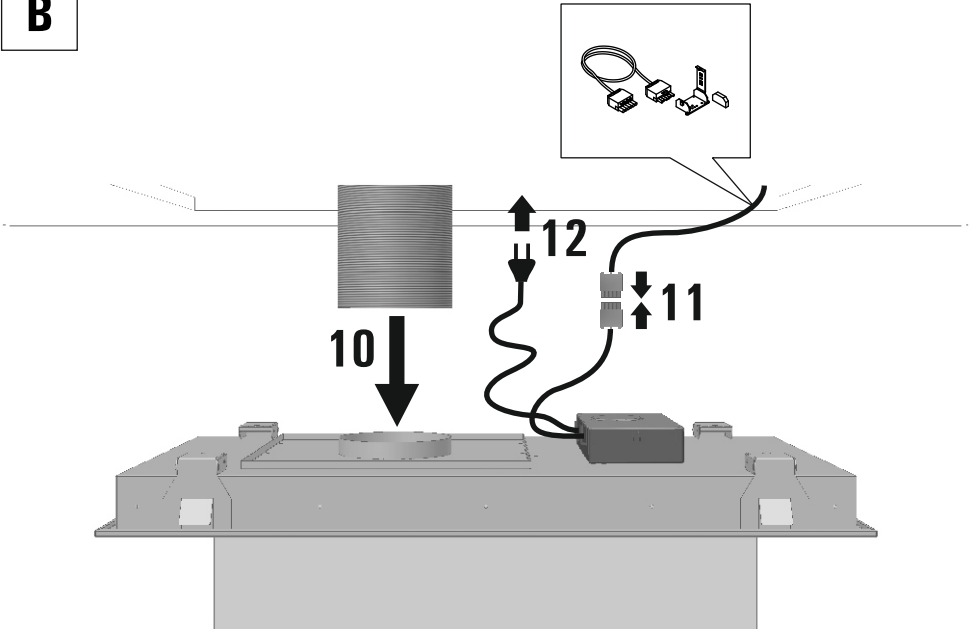

**M 9**

**B**

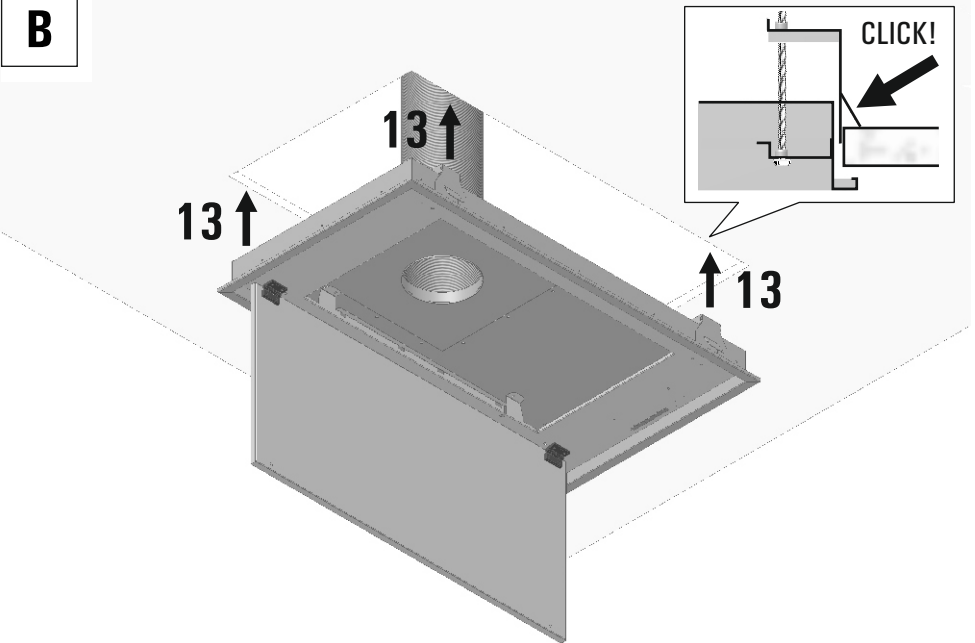

**M 10**

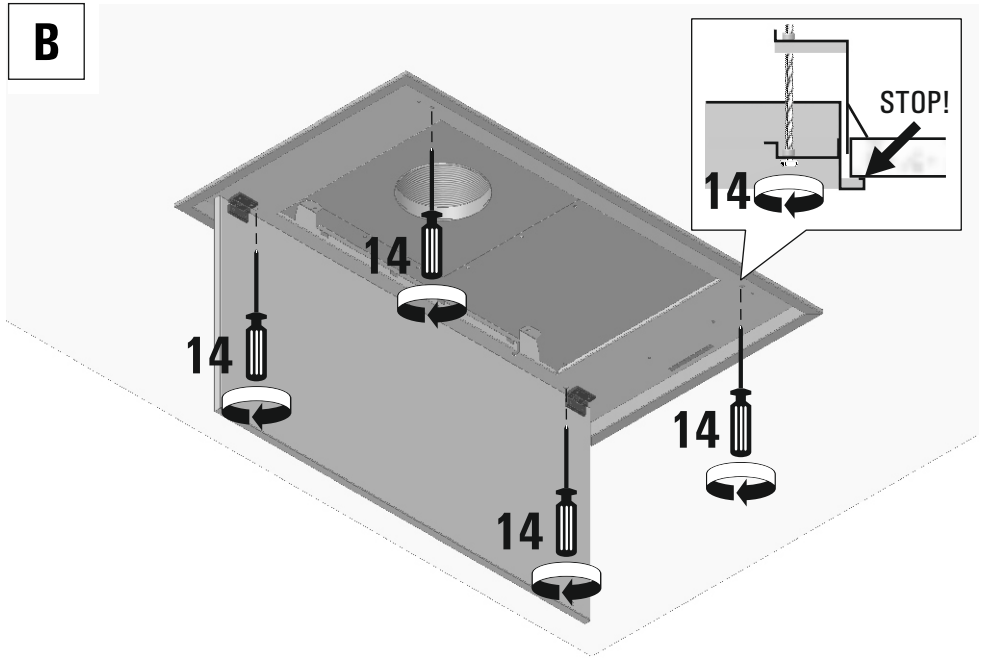
**B**

M 11

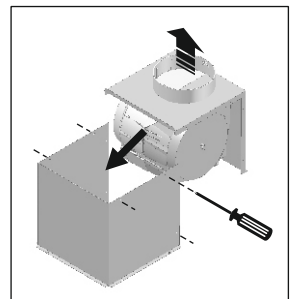
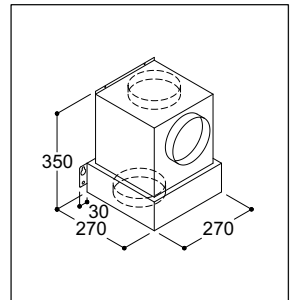
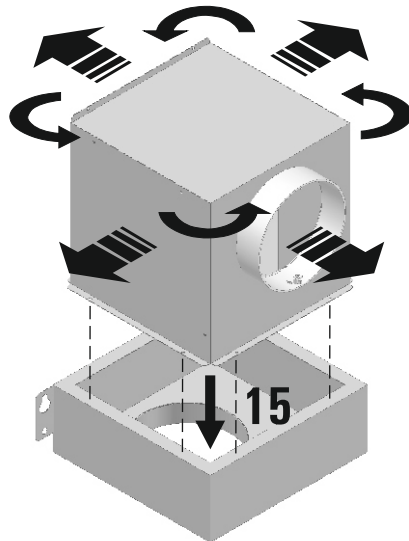
**B**

M 12

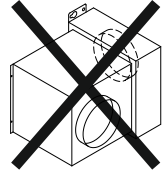
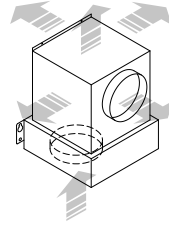
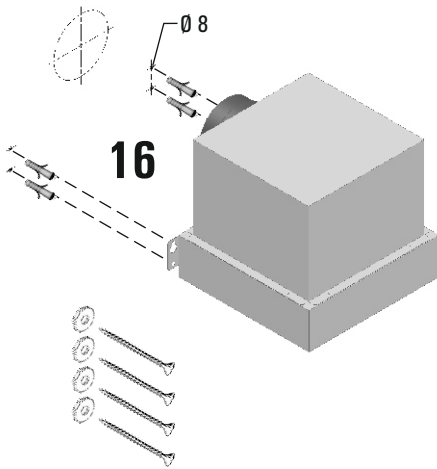
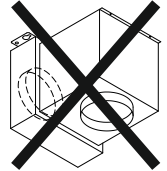
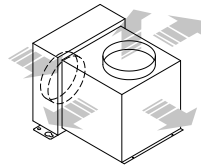
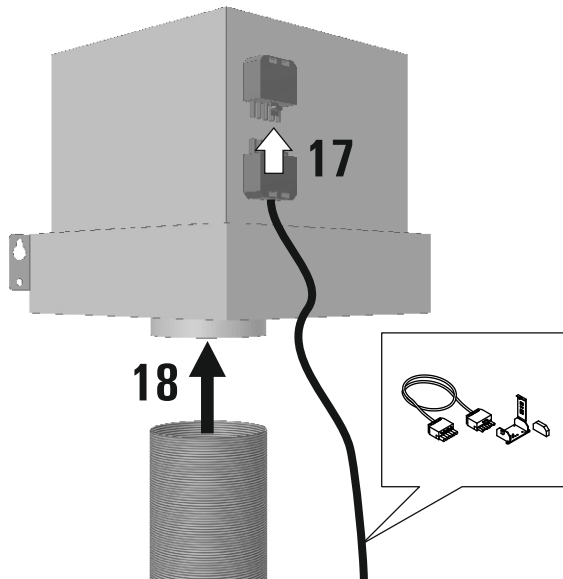
**B****Fissaggio a muro / Fixing to wall****Fissaggio a terra / Fixing to flat****M 13****B****M 14**

**A**

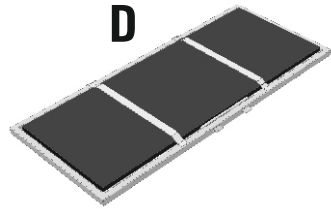
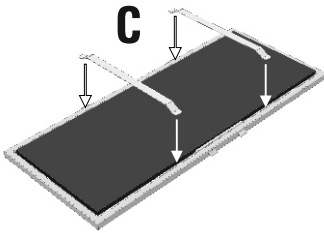
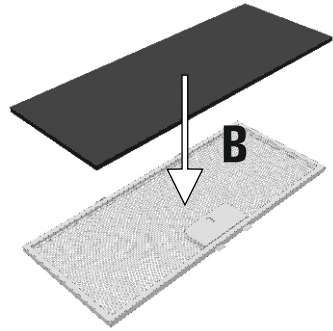
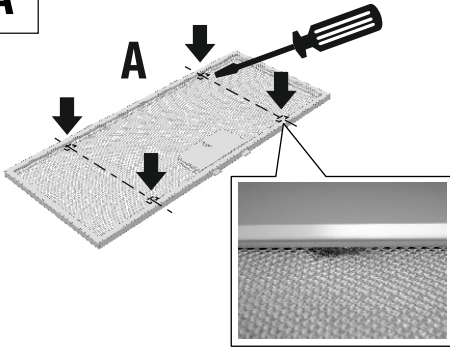

**C 2**

**Lampada alogena / Halogen lamp**

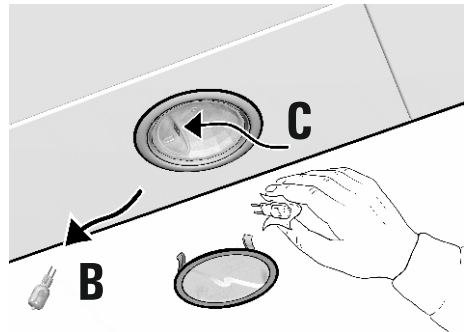
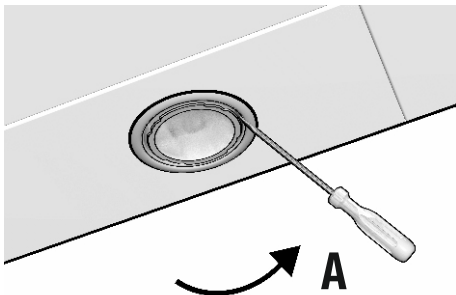

**L 1**

## Lampada led / Led lamp

